

High Performance,
Multi-format Compact, HDTV Box Camera

DK-H100



The New DK-H100 is a high-performance special application HDTV/SD camera. The camera is ideal for graphic stands point of view and remote observation applications. With its new 2.3 million pixels native 1080i 3-CCD, the DK-H100 provides outstanding performance. The camera offers sharper and cleaner HD images due to its 14-bit A/D converters and Hitachi's implementation of the latest digital processing technology. The camera achieves outstanding high sensitivity and a low vertical smear specifications.

Features

●High S/N with HD-SDI

Outstanding Signal-to-noise ratio >60dB measured on the HD-SDI (1080i) output.

●14-bit ADC with the latest generation Hitachi DSP

High dynamic range and color fidelity are achieved by employing 14-bit analog-to-digital converters on the RGB CCDs' outputs. Hitachi is a leading developer for High performance CPU & DSP in Broadcast Fields.

●High Resolution

The latest generation 2/3-inch 2.3 million pixels CCD with micro lenses and digital multi speed signal processing circuits provide a horizontal resolution performance of 1100 TV lines (luminance channel).

●Small & light weight head

●Versatile CCD shutter

- Five Preset shutter speeds
- Lock scan the camera video to images from asynchronous computer monitors, video walls or projectors without flicker
- Automatic Electronic Shutter (AES) maintains the video level with a fixed lens f-stop

●DSP provide advanced image handling and adjustment functions

- Knee saturation and auto-knee
- 12-Vector and Linear Matrix masking
- Skin tone masking
- Automatic Skin Tone Detail Circuits
- Variable Detail Boost Frequency
- Ultra Gamma
- Gray Scale Automatic Setup
- Automatic Shading Correction

●Extensive User-Friendly Features

- Full Auto
- Eight scene files are provided to store and recall functions such as gain, detail, masking, gamma and other settings
- White balance memories are provided for each Scene files for a total of nine memories by the remote control panel
- Menu access is provided for iris level (fine adjustment) and iris peak/average selection
- Computer controlled real-time auto-white balance
- ECC (Electric Color Compensating) filter

Specifications

CCD	2/3-inch, IT-CCD
Total pixels	2,010 (H) × 1,120(V) 2.3 million pixels
Effective pixels	1,920 (H) × 1,080(V)
Aspect ratio	16:9 (HD/SD), 4:3 (SD) switchable
TV signal format	1080/59.94i, 1080/50i, 480/59.94i, 576/50i
HD Resolution	1100TVL
Standard sensitivity	2000 lx / F10 (1080/59.94i), 2000 lx / F11 (1080/50i) 3200K, 89.9% reflectance
Minimum illumination	0.002 lx (F1.4/+72dB)
HD S/N	Typical 60dB (HD-SDI output decode Y channel Band : 27.5 MHz)
ECC Filter	3200K, 4300K, 5600K, 6300K, 8000K
Shutter	PRESET 1/100, 1/250, 1/500, 1/1000, 1/2000 second (59.94i) 1/60, 1/250, 1/500, 1/1000, 1/2000 second (50i)
	Lock Scan 1/59.94 to 1/10000 second, 1.07 (+36dB) to 0.03second (+6dB), (59.94i) 1/50.00 to 1/10000 second, 1.28 (+36dB) to 0.04second (+6dB), (50i)
Gain selection	L (low) -3/0dB
	M (medium) 0 to +33dB, 3dB steps.
	H (high) +3 to +36dB, 3dB steps.
Dimensions (W × H × D)	99(W) × 105(H) × 155(D) (excluding protrusions)
Power consumption	approx. 17W (DC12V)
Mass	approx. 1.5 kg (3.3 lbs)

Input signals

Genlock	Tri-level sync / BB
---------	---------------------

Output signals

HD / SD-SDI 2 output	HD-SDI : SMPTE274M 0.8Vp-p/1.5Gbps SD-SDI : SMPTE259M-C 0.8Vp-p/270Mbps
----------------------	--

- Serial data /RS-232C interface (Remote1 4-pin connector)
- RJ-45 TCP/IP control

Standard composition

Camera head DK-H100	1
Lens Mount Cap	1
Operation Manual	1

Options

Camera control panel	RU-1000VR / RU-1500JY
AC adaptor	IA-60a (I.D.X)
Lens Extension Cable	ECE-R22 (0.22m) (FUJINON)

Dimensions

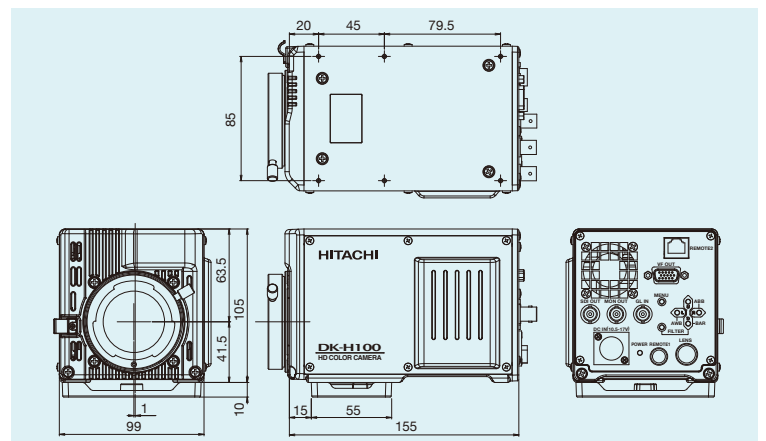

CAUTION: To ensure safe operation, Please read the instruction manual before using this product.

Hitachi Kokusai Electric Inc.

URL: <http://www.hitachi-kokusai.co.jp>

Head Office: AKIHABARA UDX Bldg. 11F, 4-14-1 Sotokanda 4-choume, Chiyoda-ku, Tokyo 101-8980, Japan
Phone: +81 (0) 3-6734-9432 Fax: +81 (0) 3-5209-5942

Hitachi Kokusai Electric America, Ltd. URL: <http://www.hitachikokusai.us>

Head Quarters and: 150 Crossways Park Drive, Woodbury, New York 11797, U.S.A.

Northeast Office: Phone: +1 516-921-720 Fax: +1 516-496-3718

West Office: 371 Van Ness Way, Suite 120 Torrance, CA, 90501

Phone: +1 310-328-6116 Fax: +1 310-328-6252

Midwest Sales: Phone: +1 330-334-4115 Fax: +1 516-496-3718 Service: +1 989-345-5379

South Sales: Phone: +1 850-934-1234 Fax: +1 516-496-3718 Service: +1 256-774-3777

Latin Sales: Phone: +1 516-682-4408 Fax: +1 516-496-3718

Parts Center: Phone: +1 516-682-4435 Fax: +1 516-921-0993

Hitachi Kokusai Electric Canada, Ltd. URL: <http://www.hitachikokusai.ca>

Head Office: 1 Select Avenue, Unit #12, Scarborough, Ontario M1V, 5J3, Canada

Phone: +1 416-299-590 Fax: +1 416-299-0450

Eastern Office: 5795 Chemin St. Francois St. Laurent, Quebec H4S, 1B6, Canada

Phone: +1 514-332-6687 Fax: +1 514-335-1664

Hitachi Kokusai Electric Europe GmbH URL: <http://www.hitachi-keu.com>

Head Office: Grütener Str.3, D-40699 Erkrath, Germany

Phone: +49(0) 2104-96550 Fax: +49(0) 2104-40039

Frankfurt Office: Siemensstr.9, D-63263 Neu-Isenburg, Germany

Phone: +49(0) 6102-83320 Fax: +49(0) 6102-202616

(Central office Europe) General email address: info@hitachi-keu.com

These Specifications are subject to change without notice.

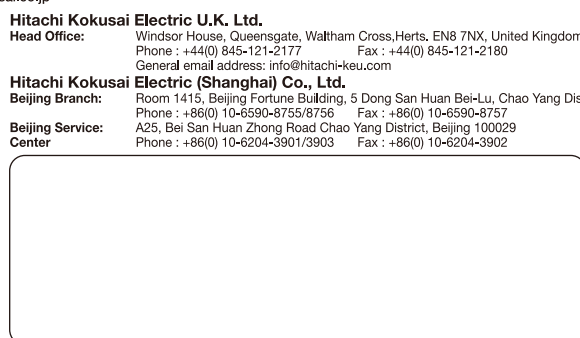

CERTIFICATE NO.
JMI-0062
ISO 9001/BS 5750P11
EN 29001/JIS Z9901